

BUILDING INSTRUCTION TABLE

FIRST® LEGO® LEAGUE CHALLENGE

At the *FIRST* LEGO League Challenge Robot Game a self-made robot has to fulfill various missions on the *FIRST* LEGO League Challenge Playing Field. For the preparation each team is provided a Challenge Set which consists of a roll out field mat (2360 × 1140 mm) and the LEGO mission models. To prepare for the challenge the field mat can be rolled out on the floor, on a self-built field mat tabletop or the self-built *FIRST* LEGO League Challenge Competition Table. This is a step-by-step instruction how to produce the table.

Material needed: Tabletop for Playing Field

- 1 pc. table surface, plywood: 20 × 1223 × 2442 mm
- 2 pcs. large field border: 40 × 80 × 2442 mm
- 2 pcs. small field border: 40 × 80 × 1143 mm
- 1 pcs. Dummy border: 40 × 80 × 300 mm (look at step 4 for use)
- Approx. 20 Large screws
- Screwdriver (cordless screwdriver)
- Clamps
- Black paint (matt) to the borders

Material needed: Subconstruction of Table (optionally)

- Additionally 4 pcs. of squared timber for stiffening for the table: max. 40 × 80 × 1223 mm
- 2 Sawhorses: high app. 750 mm
- Approx. 15 Large screws

Material needed: Lightning (optionally)

- 2 pcs. Upright: max. 40 × 80 × 1143 mm (No. "5" on drawing 4)
- Cross beam: max. 40 × 80 × 2522 mm (No. "6" on drawing 4)
- 1 fluorescent shop light 40 watt tubes
- Approx. 15 Large screws

Building Instruction: Tabletop for Playing Field

Step 1

Paint the field borders and the dummy border black.

Step 2

Lay down the field borders on the surface as shown at drawing 1.

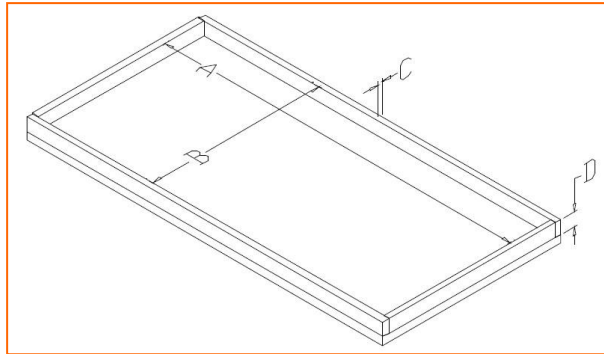

Drawing 1

Dimensions
A = 2362 mm
B = 1143 mm
C = 40 mm
D = 80 mm

Step 3

Fasten the field borders with large screws.

Step 4

Fasten the dummy border as shown in drawing 2. It is there to simulate a neighbored table. During the tournament there are two teams at a time competing at two tables fronting each other. There are mission models being placed in the center of the top of the inner field borders. If there are two tables in a tournament situation fronting each other this step is dropped.

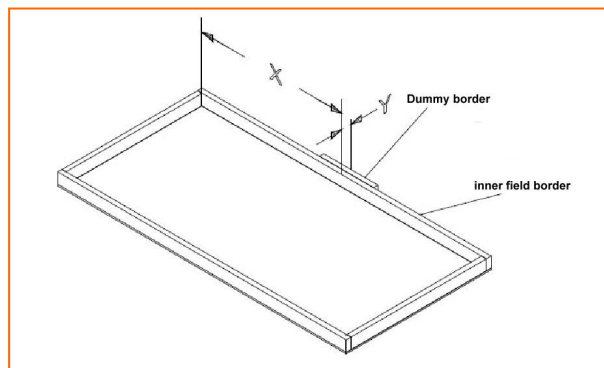

Drawing 2

Fixing of Dummy Border
X = 1181 mm
Y = 80 mm

The tabletop for the playing field is now ready. It can be placed on the floor for practicing or on a stable underground like a table. The following steps are only necessary if the self-built tabletop for the playing field should be equipped with a sub-construction or lighting.

Building Instruction: subconstruction for tabletop (optionally)

Step 5

Place, clamp and fasten the stiffeners at the bottom of the tabletop (see drawing 3), so that it builds a stable basis for the tabletop.

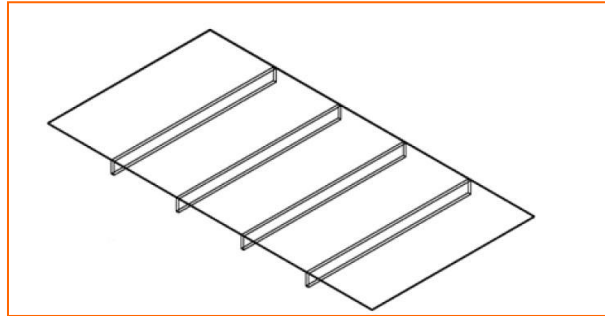

Drawing 3
Fastening of stiffeners

Step 6

With the help of another person place the whole construction on the saw horses.

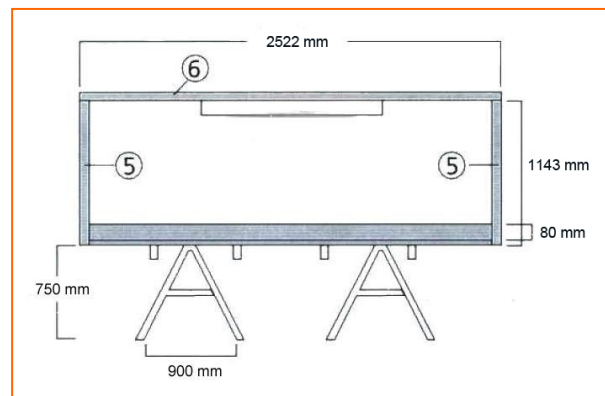

Drawing 4
Competition Table with lightning; Parts 5 and 6 upright and cross beam

Building Instruction: Lightning (optionally)

Please consider that it is not obligatory for the *FIRST* LEGO League Challenge Regional Partners to equip the tables for the tournament and preparation area with fixed lightning constructions. If you have any questions about the lighting conditions at a *FIRST* LEGO League Challenge competition, please contact the respective Regional Partner.

Step 7

As shown in drawing 4, place the wooden uprights centered at the short outer part of the table borders. Clamp and fasten them with screws. With the help of another person, situate the cross beam on top of the two uprights and screw it down. Hang the shop light e.g. by chains from the center of the cross beam.

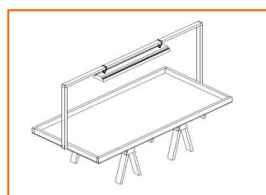

Drawing 5a
Stand-alone table

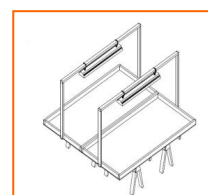

Drawing 5b
Table in competition situation